

Aerospace Frame

# Total component solutions

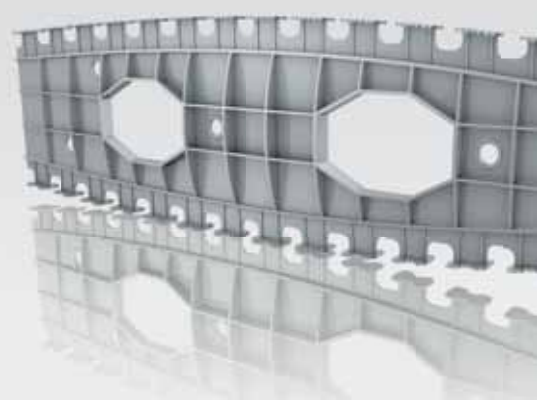

Sandvik Coromant in Aerospace

# Expertise for challenging production

## Your demands set our standards

Aerospace is one of the most technically demanding industries in the world. With increasingly difficult to machine materials, exacting specifications and constant time restraints, the manufacture of aerospace parts has many limitations - but at the same time, production rates are set to increase.

### Components and their features

Our goal is to offer complete solutions to typical components, this is both the physical tool but also the processing knowledge. In reality, a solution encompassing:

- spindle interface
- tool holder suited to access the component shape
- programming methods
- insert grade and geometry
- surface integrity - correct parameters to leave the component in the best condition

### The focus:

- 1) Reducing your non-cutting time - the only time the machine is making any money is when the 'green light' is on. This is where the adoption of machines that are more flexible, modular tooling systems and high pressure coolant will make a big impact.
- 2) Optimizing the cutting process - when programming for the first time - even if this is a prototype - this is the time to implement "best practice" for each component feature.

Our specialized Application Centers invest in the future of solutions and in the understanding of an industry that goes way beyond tools.

Sandvik Coromant in aerospace holds the expertise you need for challenging production, an expertise that puts your success in focus.



[www.aero-knowledge.com](http://www.aero-knowledge.com)

## Aerospace frame

Aerospace frame is a broad definition referring to any parts of the aerospace structure excluding the engines; a definition covering a wide variety of materials and different structural forms. Typically an aeroplane can be broken down into areas like the fuselage, wing, leading and trailing edge, pylon, tail and landing gear. Each area then consists of many different structural parts which are manufactured in different materials; titanium, composite, aluminium, stainless and high alloy steels.



## One system! One solution!

### For your entire workshop

Coromant Capto®, the smart choice for aerospace component manufacturing.

Coromant Capto is a unique coupling just as suitable for turning centre turrets as for machining centre spindles – the interface with no limitations.

This system provides the flexibility to optimize the length required to keep maximum stability and radial run out allowing high metal removal. With over 5000 standard products any tooling assembly can be built.

- Balanced and concentric
- High torque transmission
- Delivery of coolant to the cutting edge
- Stable with long tools
- Withstands high axial forces
- Quick change
- Flexible
- Automatic tool change
- No limitations on spindle rotation speed
- Without keyways
- Through tool delivery
- Good bending stiffness
- High axial clamping force
- ½ turn clamp and release
- Modularity to break down and build assemblies
- Hydraulic, gripper and magazine storable



# Fuselage - landing gear beam

On the fuselage there are several structural components produced in titanium. Here is a landing gear beam that shows the main challenges for machining these types of structural components.

## Rough face milling

Program a roll into cut in a clockwise motion (counter-clockwise will not solve the thick chip thickness problem). By rolling into cut, the chip thickness on exit is always zero, allowing for higher feed and longer tool life. A round insert cutter provides best productivity and tool life thanks to the lead angle and chip-thinning effect. CoroMill® 300 with S30T & S40T has through coolant and close pitch option, therefore optimized for titanium. Now available in insert sizes up to 20 mm (metric) or 1.0" (inch).

## High pressure coolant

The recommendation here is simple, always apply coolant when cutting titanium in large amounts and if possible at high pressure. Using high pressure coolant for milling in titanium will double the tool life compared to normal coolant pressure. The critical re-cutting of chips that damages the tool is prevented as welded chips are blown off.

### Recommendations:

- Apply coolant through spindle and tool
- Volume and pressure should be carefully planned in relation to the number and diameter of coolant holes and your operation
- Nozzle sizes should be kept small to maximize pressure
- Recommended pressure: 70 bars or more
- Recommended volume: 50 litres/minute

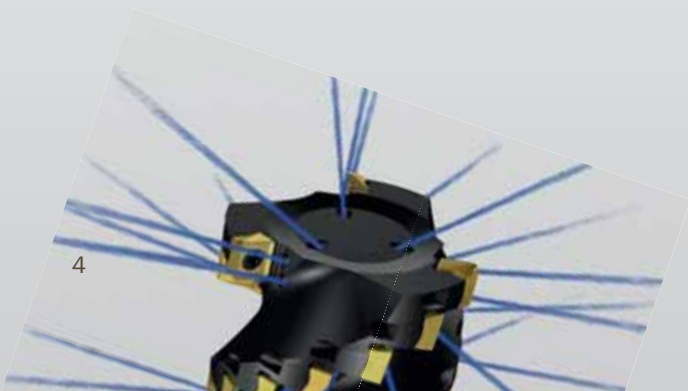
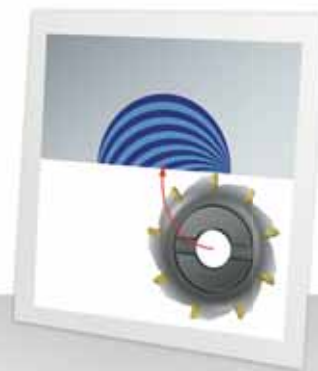
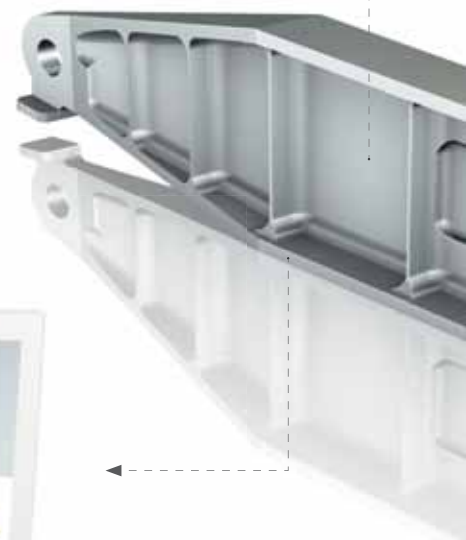

## Roughing of 2D pocket

For roughing of the 2D pocket apply the circular ramping method using low depths of cut but up to 1.0 mm feed per tooth together with the high feed cutter CoroMill 210 which provides a light and fast technique with excellent metal removal rate. It is suitable for all machine concepts and configurations. The advantages with this circular ramping method are reduced number of tools (no drills needed), flexibility - can produce a wide range of sizes. Alternative tools using the same programming technique are round insert cutters such as CoroMill 300 and CoroMill 200.

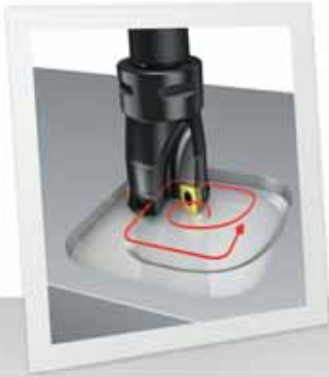

## 2D profile milling

For this operation we can provide a total solution from roughing through to finishing. The best choice for roughing is CoroMill 690 with specialized titanium grades S30T and S40T. The axial location of the inserts is built into the bottom of the insert to prevent movement and enable high metal removal rates with security. Its design makes it cut light and use minimum power. Each coolant hole is threaded to allow smaller diameter nozzles for high pressure coolant applications. For finishing we recommend the Sandvik Coromant long-edge finishing cutter, also known as the Dream cutter which gives a surface finish from 0.6 to 1.2  $R_a$  where the steps on the surface are replaced by a slight wave. The average flatness measures from 0.025 to 0.038 mm peak to valley.

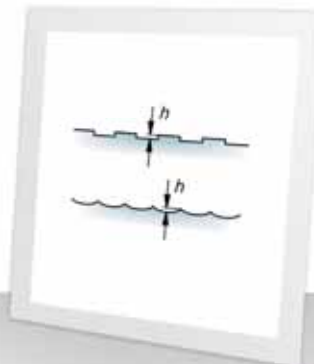

# Fuselage - central wing box

The central wing box, made out of several types of composite material, commonly stacked with aluminium and titanium challenges the manufacturing process, tool security and surface quality. Issues such as chip evacuation, effective production and hole quality, are made more difficult due to the drastic difference in material properties.

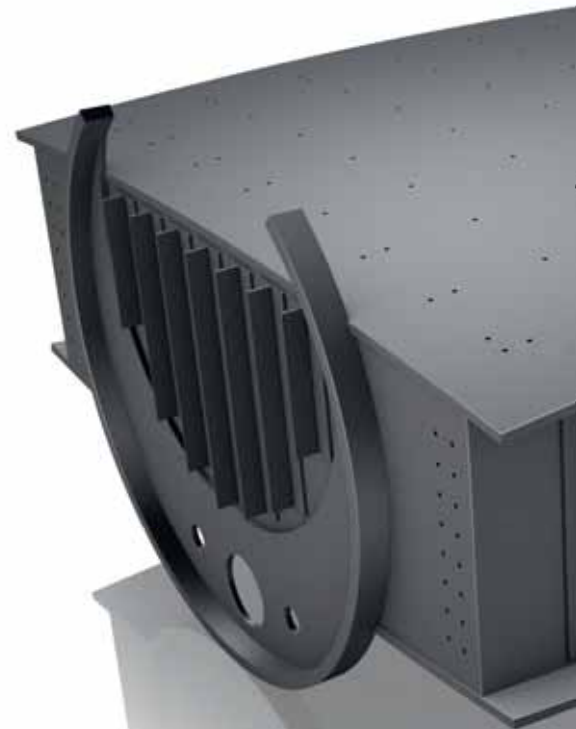

## Demanding application in stacked materials

<b>Material:</b>	Aluminium, carbon fibre, aluminium stack
<b>Application:</b>	- Hole making
<b>Hole diameter:</b>	- 9.525 mm (3/8")
<b>Drill type:</b>	- CoroDrill® 854 composite drill with diamond coating
<b>Machine type and condition:</b>	- Positive-feed machines (pneumatic) - Micro lubrication
<b>Cutting data:</b>	- RPM: 2000 - Feed: 0.03 mm/rev
<b>Hole tolerance demands:</b>	- H9
<b>Surface roughness:</b>	- Demand: 3.2 $R_a$ - Result: 1.6 $R_a$

Demands on a secure machining process with accurate dimensions, surface finish and limited burr formation were achieved with CoroDrill® 854. Long and stable tool life with excellent chip formation supported the production of high quality holes.

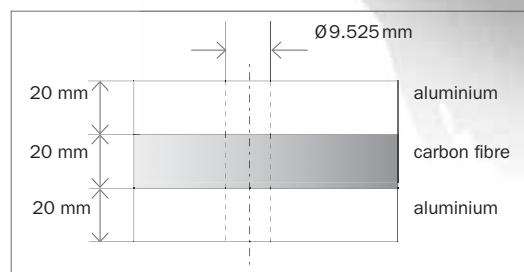

## Edging and surface machining

For edging of larger components, CoroMill® 390 with PCD inserts or diamond coated carbide inserts will increase removal rates. Using Coromant Capto® clamping units for long overhangs will increase the stability of your operation.

## Hole making in carbon fibre and metallic materials

With a focus on reduced downtime, improved hole quality and tolerance in carbon fibre, optimized drill geometries with PCD vein technology and an optimized application process are essential.

Whilst one-hit tools reducing production time is always the goal, the finishing of a hole may require a second operation. For tight tolerance holes or a demanding surface finish carbide or PCD reamers can be an excellent choice. Chamfered holes, by adding on a countersinking operation can be efficiently produced with CoroDrill® countersink tools with PCD cutting edges.

*3D model*



## Hole making in carbon fibre and titanium-stacked material

Carbon fibre stacked with titanium is one of the most demanding material combinations. The CoroDrill PCD vein drill, designed with a unique geometry, was able to raise productivity in this challenging hole making application. A sandwich of carbon fibre, with a thickness of 15 mm, layered with a 10 mm sheet of titanium was machined with good security and precision.

CoroDrill® PCD vein drill			Holemaking
Cutting speed	$v_c$	m/min	12
Drill depth	$a_p$	mm	25
Feed rate	$f_n$	mm/rev	0.05

# Wing - wing box

The main challenges for machining these types of structural components are the hole making, edging and surface machining.

## CoroDrill® geometry range

The new CoroDrill 854 for fibre rich materials, the new 855 for broad range or the new 856 geometry for resin rich materials are all designed with hole quality in mind. Optimizing the production process is simplified with a choice of geometries with optimized rake and point angles dedicated for specific materials, where demands on hole tolerance, reduced delamination and improved hole tolerance is in focus.



CoroDrill 854

CoroDrill 855

CoroDrill 856

*Tailor Made*



## Profile milling

The technique of Sturtz milling using an end mill to generate a complex surface can replace machining with ball end mills in many areas. Tilting the tool, relative to the workpiece, creates an elliptical cutter path. This shallow ellipse allows greater stepover to be used whilst maintaining the required cusp height. The process is ideally suited to large areas of shallow curvature. Sturtz milling with the CoroMill® 390 cutter and PCD insert technology, with sharp and positive cutting edges, enables high metal removal rates with good surface finish and quality providing a very secure and productive process.

## Edging of composites

The finish achieved in one operation can reduce or eliminate secondary operations, which together with tool life improvements, contributes to reduced machine downtime.

Rough machining or finishing of composite materials can be improved with CoroMill® cutters. PCD end mills and diamond-coated carbide cutters can be engineered to suit most applications, reducing splintering of fibres and increasing metal removal rates.



3D model

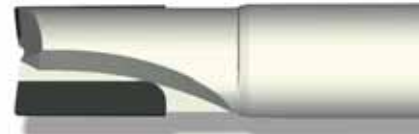

*CoroMill® Century, a high precision solution for surface machining with demands on dimensions and surface finish. Serrated seat indexable inserts make it a flexible but still accurate solution, in comparison to brazed milling cutters.*

## Surface machining with high security

Applying the high precision CoroMill Century results in a productive surface machining solution, extending production runs and security.

CoroMill® Century with PCD inserts and 4 cutting edges			Surface milling
Cutting speed	$v_c$	m/min	300
Depth of cut	$a_p$	mm	2.5
Feed rate	$f_z$	mm/z	0.17



# Wing - pylon bracket

The pylon brackets found on the wing of the aircraft can be of open and closed design. The main challenge for the closed components is the closed angle and the deep slots.

## Exchangeable-head milling system

The CoroMill® 316 end mill is the first product in line with the new exchangeable-head milling system. It is designed to work throughout a diameter range of 10-25 mm.

Better levels of productivity, versatility, inventory, quality and tool costs are the main advantages that can be achieved with CoroMill 316. The new concept provides high strength for roughing operations and high rigidity for finishing operations. Now available with solid carbide shank for long-overhang milling features.

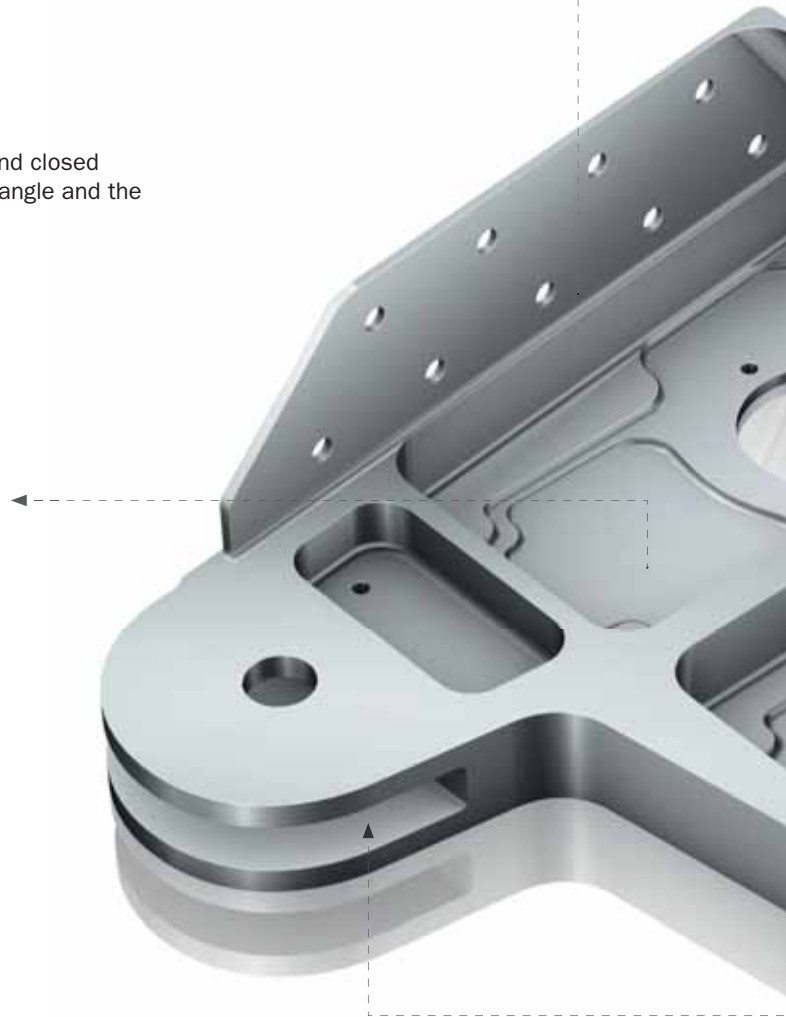

## Slotting

When the slot is deep and narrow, side and face cutters provide the best stability and productivity. The cutters can be built into a gang to machine more than one surface in the same plane at the same time. CoroMill 331 now available with S30T and S40T is an optimized solution with adjustable cartridges.

Slot milling



Shoulder milling



Profile milling



## Roughing 3D pockets with closed angles

Closed angles; less than 90 degrees, are a common component feature in pockets and cavities. Depending on the stability of machine set-up, the slicing method using CoroMill® Plura bull nose end mill or the plunging method using CoroMill 390 engineered solution is the best choice.

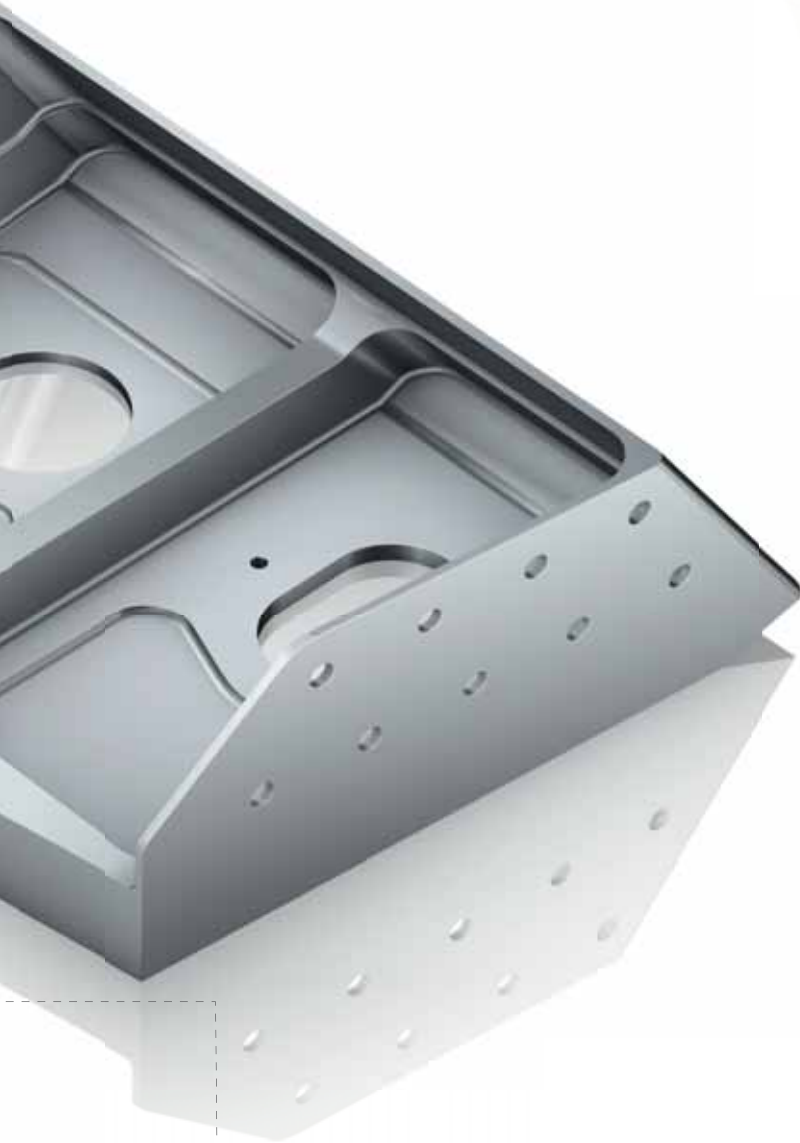

## Finishing 3D pocket with closed angles

A machine with 4 or 5 axes is needed to machine a closed angle. 4 axes: If only one side of the pockets has a closed angle and the bottom shape is flat. 5 axes: if there is a corner with closed angles on both sides and a radius at the bottom profile. The conical ball nose end mills give the choice for high quality surface finish.



# Wing - wing rib

There are several types of aluminium components on an aeroplane such as spars, skins, and ribs. The wing rib as an example shows some of the machining challenges such as thin walls/bases, 2D pockets and the importance of balanced tools.



## Thin wall machining

The machining strategy for thin wall sections should vary depending on the height and thickness of the wall. The number of passes will be determined by the wall dimensions and axial depth of cut. Use of high speed techniques, i.e small  $a_p/a_e$  and high  $v_c$  facilitates milling of thin walls, as they reduce the time of tool engagement and consequently the impulse and deflection. Step support machining the wall in overlapping passes is used when wall thickness  $v_s$  height are 15:1 to 30:1

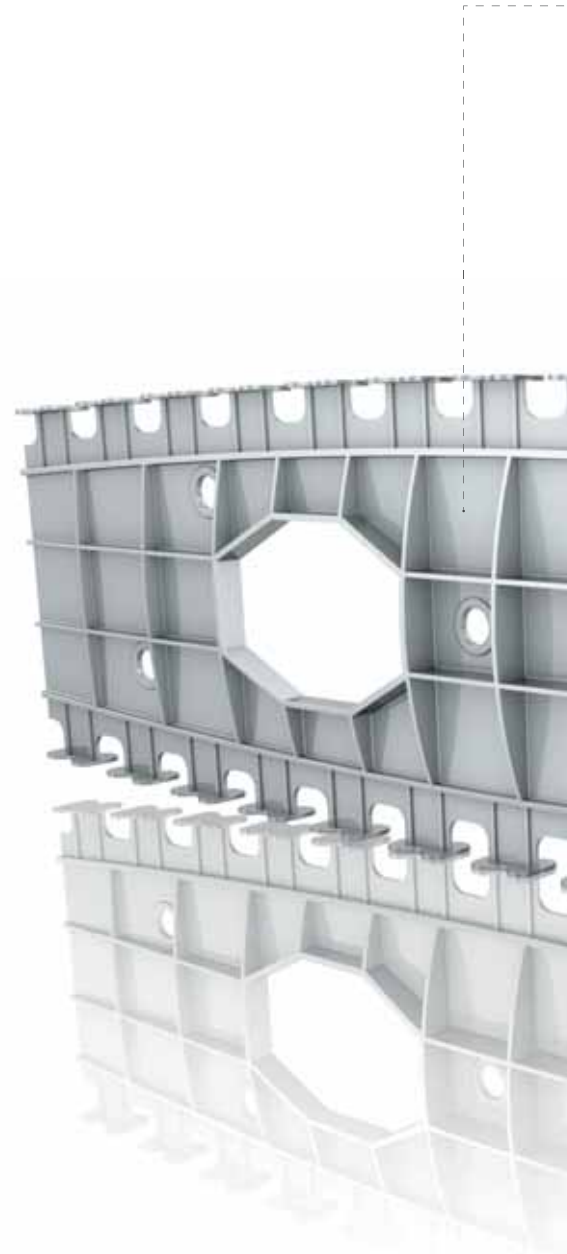

## Engineered solutions

In the competitive world of manufacturing, demands for shorter lead times, increased specialization and more complex designs appear as challenges for us in providing productive engineered solutions. As a solution provider our experience in engineered solutions has enabled our customers to reduce the number of operations and machine cycle time as well as increase component quality. Furthermore, as a result of early involvement in machine procurement activities, engineered solutions can contribute to a faster return on investment. Continued focus on major industry segments drives our future development of the engineered product offer to comprehensively support your total machining requirements wherever they are in today's and tomorrow's global world of manufacturing.



*3D model*



## Corner milling - slicing

Slicing is a method used in corner milling where multiple passes successively remove material ensuring low radial immersion/ engagement angle and low cutting forces. By applying the dedicated aluminium geometries for CoroMill® Plura or CoroMill 316 with high speed machining techniques, extreme productivity increases can be made.

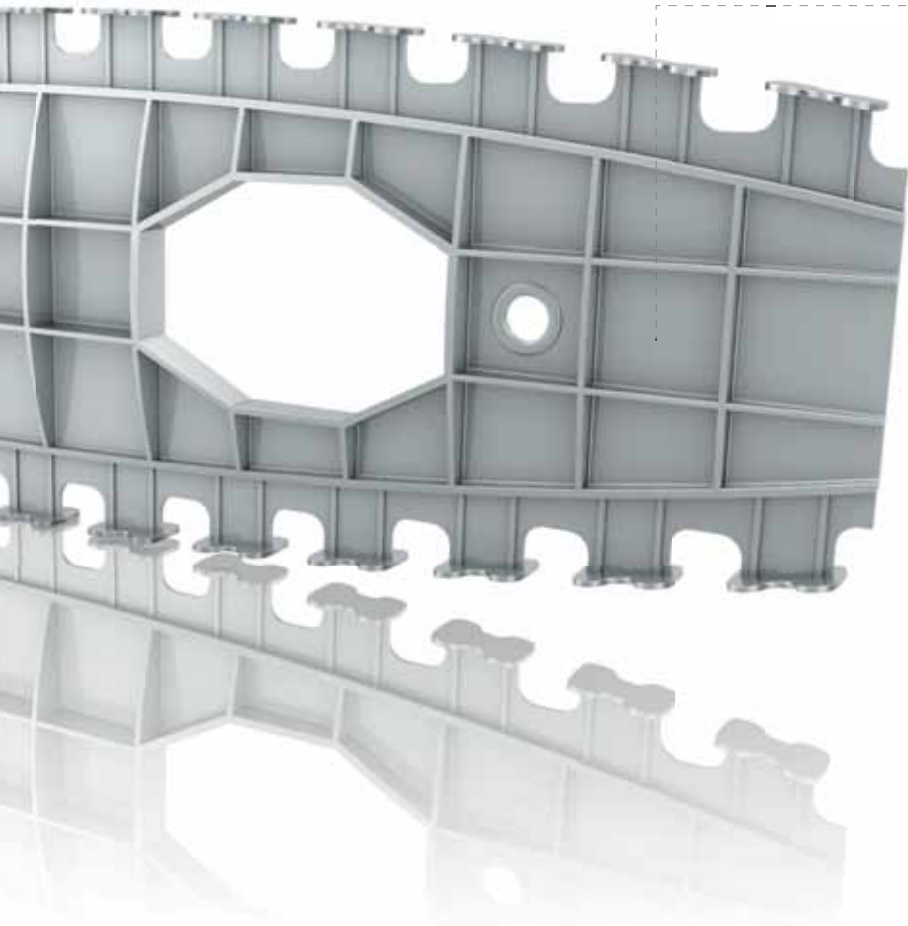

## Roughing 2D pocket

CoroMill 790 with new dedicated geometry and circular ramping method is an ideal combination when roughing 2D pockets in aluminium. With inserts firmly secured by a unique design of the support face in the insert seat, possible consequences of high radial forces, generated at high speeds, can be eliminated. This insert security also guarantees accurate location of the cutting edges - almost eliminating insert tolerance errors and thus any resulting run out.



## Tool balance

Efficient metal cutting requires that the movement of the cutting edge is precisely controlled, highly accurate and remains consistent. All forces which could disturb this control must be assessed and dealt with, including those which arise from the high speed rotation of the cutter itself. The mass of the cutter and tool holder must be evenly distributed around its rotational axis otherwise the unbalanced centrifugal forces created will cause deflection and vibration.

### The consequences of balancing to G2.5

<b>Taper 40 tool balanced with an added sticker</b>
Sticker 25 x 50 mm. $m = 0.25 \text{ g}$
Mass of tool $m_{\text{tool}} = 1.25 \text{ kg}$
Radius to sticker $r = 20 \text{ mm}$ $u = m * r = 5.0 \text{ gmm}$ $e = u / m_{\text{tool}} = 4.0 \text{ }\mu\text{m}$
Balance class at 15 000 rpm $e * n / 9549 = G6.3$
Unbalance force at 15 000 rpm $u * (n / 9549)^2 = 12 \text{ N}$

# Trailing edge - carriage

The carriage is a key component on the trailing edge. These are normally produced in titanium. The main challenges are the unstable conditions due to component geometry.

## Dedicated titanium milling grades

S30T and S40T are available for a variety of CoroMill® cutters for face milling, shoulder milling, long-edge milling, plunging, high-feed milling, profiling and slot milling. Together these grades amount to a new level of reliable long lasting performance.

### Grade S30T for speed and tool life

S30T has been developed with productive titanium milling in focus. It combines the properties of micro-grain carbide and a wear resistant PVD coating. This enables very sharp cutting edges that resist fatigue and micro-chipping and result in cutting edges that are preserved for longer times in cut at higher cutting speeds.

### Grade S40T for difficult conditions

S40T is developed for difficult conditions combining high toughness cemented carbide with a thin CVD coating. The result is a grade that withstands vibration and other difficult cutting conditions for longer times in cut. The wear is predictable, making the cutting edge gradually duller without breaking.



## Corner milling - slicing

CoroMill Plura and slicing method is the ideal combination when machining corners in titanium components. Multiple passes successively remove material ensuring low radial immersion/engagement angle and low cutting forces.



## Roughing of 2D pocket

Opening up a 2D pocket with spiral morphing method using the CoroMill 390 long edge with 11 mm size insert and new titanium grade S30T provides excellent metal removal rates. Keep arc of engagement low when pocketing - produce a large entering hole (made by either drilling or helical ramping), roll into cut, then program with large corner radii to avoid vibration in corners.



## CoroMill® 690 with new grade S30T

Component: Pylon  
 Operation: Roughing shoulder  
 Material: Ti-6Al-4V, 350 HB, forged, through hardened  
 Tool: Competitor / R690-10  $D_c$  80 int  
 Coolant: High pressure coolant

Insert grade	Competitor	S30T
Cutting speed, $v_c$ (m/min)	73	60
Rpm	290	238
Table feed $V_f$ (mm/min)	232	232
$z$	5	5
Feed/ tooth, $f_z$	0.16	0.19
Max chip thickness, $h_{ex}$ mm	0.12	0.16
Depth of cut, $a_p$ mm	45	45
Radial depth of cut, $a_e$ mm	10	10
Tool life (min)	60	84
Tool life (components)	10	14

Result: CoroMill 690 equipped with grade S30T makes 40% more parts than competitor.

# Leading and trailing edge - flap and slat track

The flap track and slat track are components in the leading and trailing edge mechanism. These components are normally produced in high alloy steel and stainless steels such as 15-5 PH, maraging steel etc.



## Milling of 2D pocket

CoroMill 390 end mill - size 17 mm insert, together with grades GC2040/GC4240 is an ideal choice for the 2D roughing of the pocket. The size 17 insert comes in a radius range of 0.4-6.4 mm.



## Application hints stainless

### Roughing

- Use high cutting speeds ( $v_c = 150-250$  m/min) to avoid built-up edge.
- In roughing we recommend running dry, without cutting fluid, to minimize problems with thermal cracks.

### Finishing

- In finishing, cutting fluid, or preferably mist coolant/minimal lubrication, is sometimes necessary to improve the surface finish. There are fewer problems with thermal cracks in finish milling, because the heat generated in the cutting zone is lower.
- With a cermet grade, CT530, sufficient surface finish can be obtained without cutting fluid.
- A feed,  $f_z$ , that is too low can cause higher insert wear because the edge is cutting in the deformation hardened zone.



## ▶ Face milling

Enter the workpiece smoothly with CoroMill® 345 by lowering feed to 50% until the cutter is fully engaged. This high performance tool is equipped with an 8-edged insert for the best economy and productivity. CoroMill 345 (up to diameter 125 mm) has coolant supply to each insert pocket ensuring good chip evacuation for the best performance when machining demanding materials.



## ▶ 2D profile milling

The best choice for roughing the 2D profile is CoroMill 390 long edge with 18 mm size insert and specialized grades GC2040 and GC4240. The CoroMill 390 with 18 mm insert has a tougher edge for higher feeds and heavier applications. It is also available in a wide range of radius inserts.



## Slotting

The CoroMill 331 is the ideal solution when machining the deep slots in the flap track. Spring-loaded cassettes provide easy setting for desired width. Cutters are delivered within 0.01 mm width. To achieve a close tolerance, use the H tolerance inserts. Round insert options and a vast assortment of corner radii.



# Pylon - thrust fitting

The thrust fitting is normally produced in titanium and is located between the wing and the engine. The main challenge is the machining with long overhang tools.



## Finishing external circular ramping

Compared to internal circular milling/ramping:  
 The tool centre feed,  $v_f$ , is increased instead of reduced. The radial depth,  $a_e$ , becomes much smaller when milling externally, therefore, a higher cutting speed can be used.  $h_{ex}$  is calculated in the same way as for edging. The programming technique is otherwise very similar to internal milling of holes. CoroMill® 790 with GC1010 with high ramping capability generates straight shoulders with minimal mismatch and very low cusps when passes are repeated.



## CoroMill® 690 vs cobolt long edge

Material: Titanium alloys – Ti6Al4V

Component: Structural

Coolant: External

The CoroMill 690 achieves 136% higher metal removal rate vs competitor. The operator said “Besides the tremendous productivity increase we also have eliminated regrinding of the competitor cutter”

	Competitor	Sandvik Coromant
Tool:	Cobolt long edge - 6 teeth	CM690 Dia 50 - 3 teeth
Insert:	Competitor	R690 – IC 10
Grade:	Competitor	S30T
$v_c$ :	25 m/min	55 m/min
$f_z$ :	0.07 mm	0.15 mm
$v_f$ :	67 mm/r	158 mm/r
$a_p / a_e$ :	50/15 mm	50/15 mm
Q:	50 000 cm <sup>3</sup> /min	118 000 cm <sup>3</sup> /min



— = program table feed

— = rapid traverse



## 2D profile plunging

Working with the z-axis is not a first choice when conditions are stable. But conditions are not always stable and plunging is a good solution for weaker set-ups and long overhangs. To maintain a good degree of productivity, it is important to be able to take a reasonable step over. Coromant plunge cutter has maximum step of 22 mm.

## 2D profile milling long overhang

The Coromant Capto® modular tool holding system enables tools to be assembled to the required length, while maintaining high stability and smallest run-out. Keep the tooling assembly as rigid and short as possible. Choose the largest possible adaptor diameter/size. Use Coromant Capto adaptors with oversized cutters to avoid reduction adaptors. For small milling cutters, use a tapered adaptor if possible.



# Pylon - engine mount

The most difficult feature on these engine mounts is the deep slot in the centre. Depending on the conditions, different methods can be used.

## Hydro-Grip® heavy duty

Hydro-Grip heavy duty provides stable tool holding for demanding machining. A strong clamping force makes it perfect for heavy roughing operations with the highest level of power and stability of a hydraulic power chuck.

## Application hints titanium drilling

### Short through holes – dia smaller than 12 mm

- Use CoroDrill® Delta-C, geometry 846 and grade GC1220
- High pressure coolant recommended where chip forming or chip evacuation problems occur
- Use HydroGrip high performance chucks for maximum stability

### Short through holes – dia larger than 12 mm

- Use CoroDrill 880, geometry LM
- First choice grades for diameters 12-16.49 mm are GC1044 centre insert, GC4044 periphery
- For diameters 16.50-63.00 mm the first choice grade is H13A for the periphery insert. For the centre insert H13A should be used if uncoated inserts are required. Otherwise GC1044 gives longer tool life
- High pressure coolant if chip forming or evacuation problems occur



## ▶ Drilling

CoroDrill 880 is the first choice drill for high productivity and low machining cost per hole with high penetration rate. The drill has been developed for up to 100% higher productivity, closer hole tolerance and improved surface finish. The CoroDrill 880 has four true cutting edges with wiper geometry on the peripheral insert offering better surface finish.



## Deep slotting different methods

### Solution 1:

If the conditions are stable and the machine has enough power and torque the CoroMill 331 is the ideal choice. This multi-purpose side and face milling cutter has high-precision capability.



### Solution 2:

Light and fast method using the high feed cutter CoroMill 210. High feed cutters are being employed to a great extent on lighter machines for a light and fast approach. Low depth of cut but up to 1.0 mm feed per tooth provides good metal removal rate.

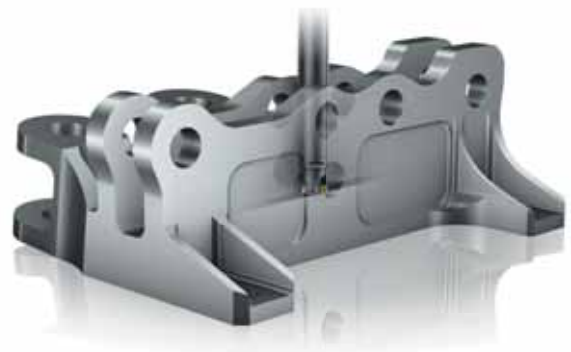

### Solution 3:

Plunging is a good solution for weaker set-ups and long overhangs. To maintain a good degree of productivity, it is important to be able to take a reasonable step over. The engineered special plunge tool using the CoroDrill 880 inserts can be a good problem solver.



3D model

# Landing gear - main fitting

Typical landing gear components are main/nose/centre fitting, piston/slider, truck/bogey beam, drag brace and links. The main materials are high alloy steels such as 300M. But there is a trend that these will be produced in titanium alloys such as Ti-5553. The main challenges in the main fitting are deep hole drilling, internal turning and profile milling.



## Deep hole machining

The T-MAX 424.10 has setting possibilities on the diameter with exchangeable cartridges and shims. Close diameter tolerance and high surface finish. Standard diameter range 65-130 mm, Tailor Made diameter range 130-183.99 mm and wide range of engineered solutions Diameter range 184.00-327.99 mm on request.



## CoroMill® 690

Material: Titanium alloys – Ti5Al-5V-5Mo-3Cr  
Component: Engine strut  
Coolant: External  
Productivity increase: 40%  
Increased tool life: 100%

The competitor achieves 50 minutes in cut and CoroMill 690 achieves 85 minutes in cut. The operator said "The competitor cutter has a tendency to move the component, compared to the new Coromant Long Edge which is much smoother cutting".

	Competitor	Sandvik Coromant
Tool:	Competitor	CM690 Dia 84 - 5 teeth
Insert:	Competitor	R690 - IC 14,5
Grade:	Competitor	GC1030
$v_c$ :	21 m/min	21 m/min
$v_f$ :	2 mm/r	2.8 mm/r
$a_p / a_e$ :	50-75/20-75 mm	50-75/20-75 mm
Tool life:	50 min	85 min



## Profile milling

CoroMill® 216 is a robust ball nose end mill perfect for semi-finish profile milling, available cutter dia 10-50 mm. The cutter has inserts with two edges for effective and general contouring and copy milling. Maximum depths of cut up to 44 mm and max feed per tooth up to 0.6 mm. For titanium components it is now available with S30T.



## Internal turning

A standard Silent tool boring bar programme up to 250 mm diameter and 14 x dia to length capability is available. This range of tools can produce component features of an extraordinarily high standard. The serration lock coupling is now equipped with a full range of cutting heads with high pressure coolant capability. The first choice grades are GC4225 for roughing and CB7015 for finishing.

Silent Tools®



Proven solutions. Documented results.  
[www.aero-knowledge.com](http://www.aero-knowledge.com)



For more information please check our catalogue supplement or visit [www.aero-knowledge.com](http://www.aero-knowledge.com)

Head office:  
AB Sandvik Coromant  
SE-811 81 Sandviken, Sweden  
[www.sandvik.coromant.com](http://www.sandvik.coromant.com)  
E-mail: [info.coromant@sandvik.com](mailto:info.coromant@sandvik.com)

C-2940:131 ENG/01  
Printed on recycleable paper. Printed in Sweden, AB Sandvikens Tryckeri. © AB Sandvik Coromant 2010.01



Your success in focus